

LAN eXtensions for Instrumentation

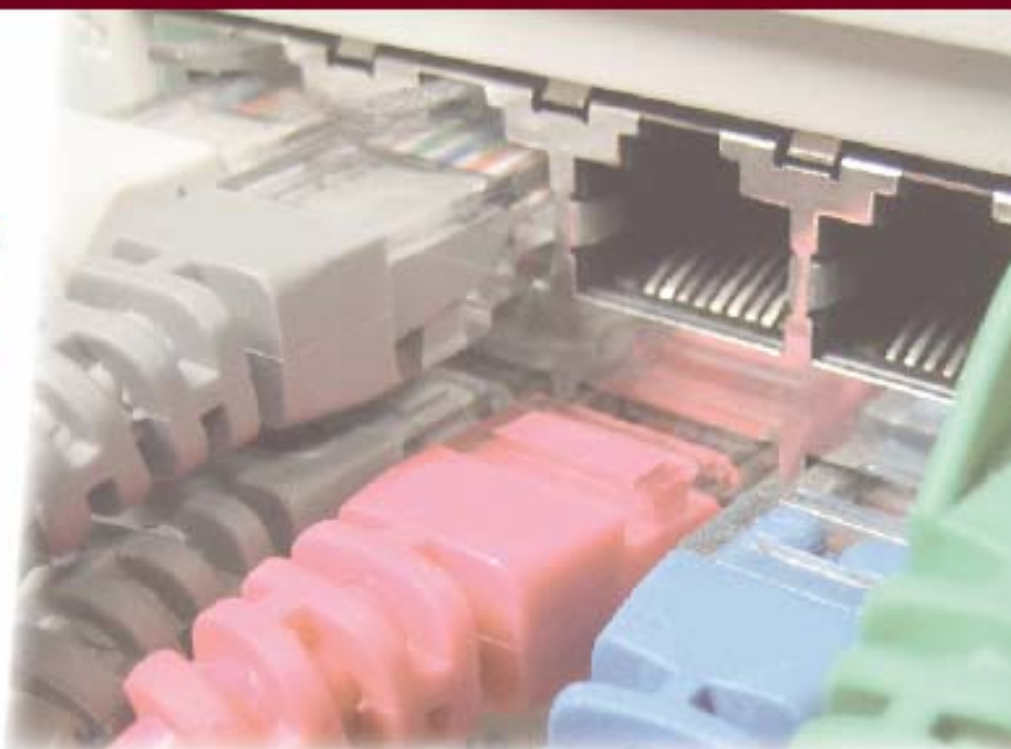

**Wired Trigger Bus Physical Aspects, Revision 1.0,
December 20th, 2005**

White Paper No. 3

Contents

- Introduction
- Connecting LXI Devices Together
- WTB cable assembly
- WTB Terminator
- Driving the WTB
- Driven Mode
- Wired OR
- Wired OR Bias Device
- Trigger Modes
- Trigger Bus Length Limitations
- Star Hub

David Owen
Pickering Interfaces
20th December 2005

Wired Trigger Bus Physical Aspects

This white paper provides information about the physical aspects of the wired trigger bus used in the LXI standard and provides some background on the decisions that were made concerning its implementation. The paper does not contain performance related information which can be found elsewhere.

Introduction.

The wired trigger bus (WTB) provides a means of connecting LXI devices together in a way that allows them to exchange hardware trigger signals that have low timing uncertainty. It provides a standardized way of providing the trigger signals previously used on bench (and other) instruments based on a physical connection (such as a coaxial lead). These traditional methods were all based on ad hoc definitions requiring the user to understand the trigger signals generated by one device and what the receiving device needs to make a trigger event happen.

The physical interface for the WTB is based on the TIA/EIA-889 Multipoint Low Voltage Differential Signalling (M-LVDS) standard. This standard uses differential current driven signals to exchange data between semiconductor devices. It is intended primarily to interconnect devices on a PCB or (typically) devices over short distances with ribbon style cables. For instrumentation use the WTB working group of the LXI Consortium has altered the way the transmitter and receiver devices work to allow it to provide a robust wired OR function and defined a cabling and connection standard to permit its use over long distances.

The WTB provides 8 physically independent trigger channels, matching the number of logical channels provided by the other trigger mechanisms in the LXI standard. The channels are designated as LXI0 to LXI7.

The WTB is part of the LXI trigger system. Trigger events made through the WTB can alternatively be made through the LAN based trigger system - the trigger model is designed to be as consistent and interchangeable in each mode of operation as possible. There are important differences in performance that a user needs to be aware of due to the fact that the WTB is based on a dedicated bus interface:

- The trigger delay from one event occurring and initiating action elsewhere is dominated by hardware delays on the bus cables and associated routing logic.
- LXI devices are likely to connect the trigger bus signals as directly as possible from the interface to the hardware performing the task.
- Once set up there are likely to be no software or firmware related delays in reaction times.

The WTB exhibits both low trigger delay and low trigger jitter and performance levels which are not achieved through the LAN based trigger mechanisms.

In addition to supporting high performance trigger operations the trigger bus can also be used to exchange clock signals or other data signals between LXI devices.

Connecting LXI Devices together

From the outside of the LXI devices the WTB is a relatively simple arrangement. Each LXI device has two connectors typically on the rear panel. Electrically these two connectors are directly wired together (there is no electrical buffering), so there is no in or out. Both connectors have the same electrical function and can be freely interchanged. The connectors may be side by side or stacked one above the other, and while both configurations are acceptable, the stacked configuration is generally preferred due to its compact size and slightly better performance.

Cables are used to connect the output trigger of one device to the input of the next device in a

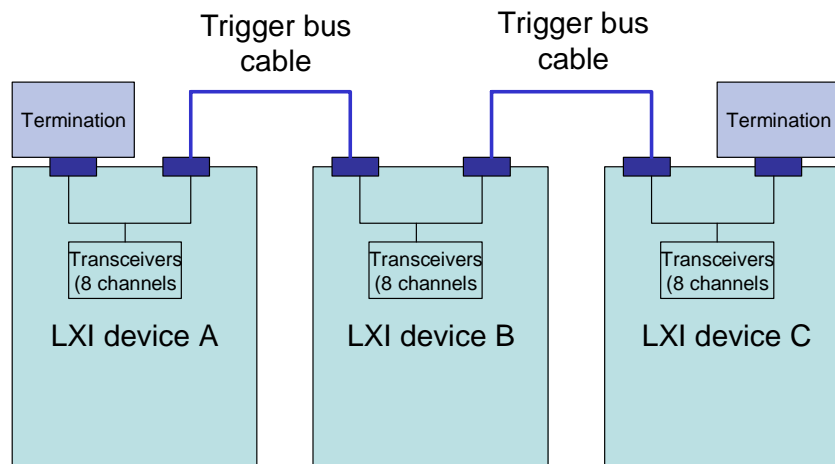

Figure 1 Connecting three LXI devices trigger bus' together with two trigger bus cables and terminating the bus with terminators at each end. The trigger bus cables are continued within the LXI device to form a single transmission arrangement.

daisy chain arrangement. The interconnection cable used has a defined characteristic impedance and has to be certified to be compliant with the LXI standard. The connectors on each device are standardised to be a 25 pin micro-D type, so the same cable assemblies can be used with any LXI device, the only variable is their length. The LXI standard ensures that the trigger bus connections within the LXI device maintain the required transmission line impedance and that their impact on bus performance is minimized.

The connection arrangement forms a transmission line and, like all transmission lines, it has to be correctly terminated to avoid reflections. When a device on the WTB tries to drive the cable the signal immediately splits into two and travels down the daisy chain in each direction until it reaches a termination at the far end. The last device on each end of the daisy chain has to correctly terminate the transmission line with minimal reflections, so the second connector has to have an LXI Termination fitted. An LXI Termination is defined in the standard and has to conform, so any compliant LXI Termination can be used.

WTB cable assembly.

The WTB cable uses a set of twisted pairs of wires, each pair having a shield surrounding it. A total of 8 twisted pairs carry the 8 physical trigger channels inside an outer screen and a protective jacket. The cable construction is specified in the standard to ensure that it has the right characteristic impedance and loss factors. The wire used in the cable is particularly important, it must have a highly conductive finish to ensure minimal loss at high frequencies where the skin effect may adversely effect the performance of the trigger system.

The construction of the cable ensures that emissions from it are very low. The differential signals it carries ensure that there is little net radiation from the wires and the shields ensure that what radiation there is will be further attenuated. The shields also ensure that crosstalk between the 8 physical channels is minimized, an important consideration on long cable runs where crosstalk can generate timing jitter.

Provided the LXI Trigger cable assembly is certified as compliant to the standard, the user need have no concerns over the detail of the build of the cable. Since the cable assembly needs the use of specialised tooling and careful attention to the build standard, it is unwise to use anything but a purchased assembly from a reputable supplier.

WTB Terminator

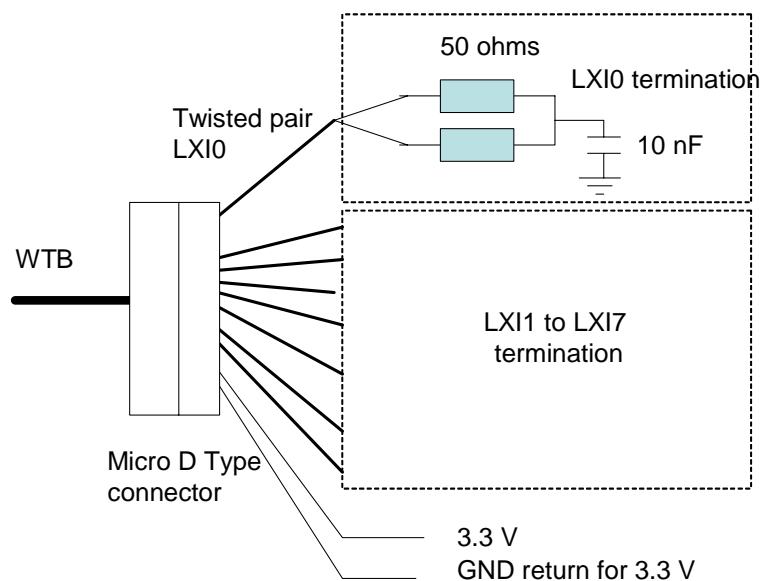

Figure 2 Schematic representation of a wired bus terminator. Each twisted pair representing a trigger bus channel is terminated by a pair of resistors and a capacitor. A 3.3 V voltage and its ground return are also provided. The ground wires for the shield of each twisted pair are not shown.

As already noted, each end of the daisy chain needs to be terminated. The termination of each of the 8 channels uses two 50 ohm resistors in series across the differential wires with the centre tap (AC ground) decoupled to ground with a capacitor. The two 50 ohm resistors terminate the differential mode transmission line impedance in 100 ohms at each end. The centre tap decoupling results in the common mode transmission line being terminated in 25 ohms at high

frequency. This decoupling ensures that any common mode disturbance caused by imbalance in the current mode drivers is minimised.

The WTB connectors on the LXI device also provide a +3.3 V power output and return which can be used to provide additional functionality in a terminator. The current is limited to 100 mA. This power connection must not be carried through to the cable.

Although it is possible for users to make their own terminations it is discouraged, commercially available terminators will be compliance tested and inexpensive.

Driving the WTB

The drivers in the LXI devices must use parts which comply with the TIA/EIA-899 standard. These IC's use differential current outputs, when one of its outputs is a current source the other is a current sink. The current is terminated by the differential transmission line impedance so it produces an approximately symmetric voltage swing about AC ground on the two differential wires.

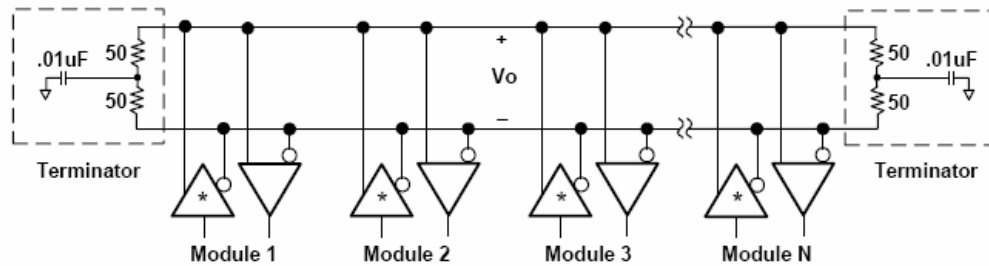

Figure 3

Representation of a single physical channel of the WTB with transceivers in the LXI devices driving the bus transmission line. The drawing does not show the detail of the transceiver arrangement, two drivers are needed in the LXI device to drive the transmission line in wired OR mode.

The use of a differential current drive means that if there is a noticeable common mode voltage between two LXI devices then little additional current flows in the cables and the signals are correctly received by the differential receivers. It helps ensure the cable emits little radiation and has high immunity to external fields.

Each of the 8 physical channels of the WTB has two drivers and one receiver connected to it. The reason for having two drivers will become apparent when considering the Wired OR mode of operation to be discussed later. Each of the drivers can be set high or low (driven) or can be set to a tri-state condition (the outputs are disabled). The receivers are always connected to the bus and monitor its state.

Note: The physical implementation in an LXI device may result in two receivers being connected to the bus because of the chosen drivers. The second receiver is not used.

The receivers are specified to be Type 1 devices under the M-LVDS standard. The output of a Type 1 receiver is defined to be high for differential input voltages above +50 mV and low for input voltages below -50 mV. If none of the LXI devices are driving a particular physical channel the differential voltage on the channel will be approximately zero volts (forced by the differential termination). This places the input voltage in the middle of the transition region of the receiver

and therefore the receiver's output is undefined. For this reason, regardless of the mode (Driven or Wired OR), whenever a channel is enabled, the bus must be driven either high or low at all times to avoid being in the transition region. In Driven mode this happens naturally, but in Wired OR mode, where the drivers are turned off to generate a logic low, the bus must be driven low by a designated bias device.

Note: Early versions of the standard considered using Type 2 receivers which have a positive differential offset on their input switching threshold. However, this offset was found to increase timing skew and decrease signal margins in the system. In addition, changes to the way that the Wired OR system works made the use of Type 2 receivers unnecessary.

The bus itself is driven in one of two ways a so called Driven mode and a Wired OR mode.

Driven Mode

The Driven mode is the simplest to understand. This is a point to multipoint mode of operation. One LXI device drives the selected physical channel to a known state, other devices are set to "listen" on that physical channel.

Note. An LXI device can be driving one physical channel and receiving on that same channel. An LXI device can also be driving one or more physical channels while receiving on other physical channels.

The Driven mode cannot have two drivers on the same physical channel. If two are set to driven mode the current outputs will fight and the one with the biggest current capacity (by chance) will set the state. The trigger bus on that channel will not behave in the expected way.

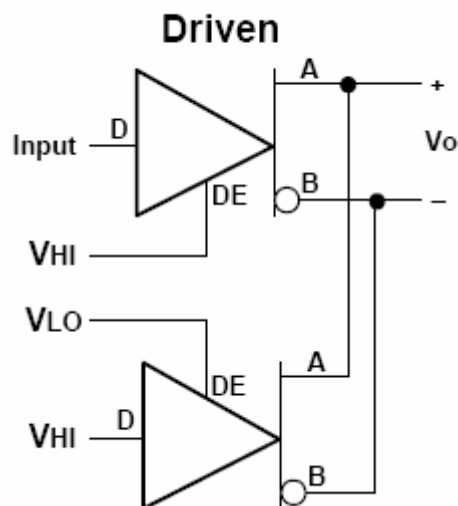

Figure 4 A typical arrangement for the two output drivers in the driven mode of operation. The upper driver is driven by the trigger signal from the LXI device. The lower driver is disabled by setting its Device Enabled (DE) low, sending that driver to the tri-state condition. Only the upper driver is driving the trigger bus. For driven mode only one LXI device can drive the bus at a time since if two devices attempted to drive the bus it would result in bus contention.

The driven mode is useful when the system is waiting for one device to initiate an action in the system. The event can be started because one of the other LAN based triggers initiated it making all the devices connected respond in a synchronized way without additional timing uncertainty or because the LXI device detected some physical event that requires the system to capture information. This latter scenario is very familiar to bench instrument users since it includes the triggering of scopes to record events.

Some LXI devices can be programmed to combine several trigger events and issue conditional trigger signals so that action is only taken under a combination of circumstances. While the LXI specification recommends such features, they are not required and may be device dependent.

The driven mode of operation will also be very familiar to users of the PXI standard since it uses a trigger bus that operates in a similar way. In the PXI case the 8 physical channels are voltage driven and therefore all are point to multi-point triggers.

Wired OR

The second method of operation provides functionality that is familiar to that achieved on the VXI trigger bus, but with much higher performance levels.

The Wired OR mode is a multipoint to multipoint method of triggering that has required some adaptation of the M-LVDS standard. A typical use case demanding Wired OR operation is where several instruments are monitoring events and the first one to detect an event triggers all the others to capture data or perform certain tasks. A second typical use case is where a system is waiting for a number of devices to indicate that they are ready to take measurements, the last one to be ready starts a triggered operation in the others. A Wired OR capability provides a very simple way of providing this facility without resorting to complex ways of gating trigger signals together in the devices and maximizing the number of channels available to perform the various trigger operations. The Wired Trigger working group of the LXI Consortium expended considerable effort in ensuring that a robust method of implementing Wired OR was available.

The Wired Trigger operation on VXI is accomplished using an open collector drive system. For LXI the operation is a little different since it uses differential signals based on the M-LVDS standard.

Starting with the use case where the first device to trigger initiates an action, all the devices participating in the trigger generation set their drivers to the tri-state condition on that physical channel. Normally this would mean the trigger bus would be forced to a mid voltage (no current) state that is close to the threshold voltage of the Type 1 receivers. However, an additional device on the bus is set to be a Wired OR Bias Device that forces the trigger bus to the low state. The low state is set by a single M-LVDS driver. To overcome the bias device, each LXI device participating in the trigger initiation uses two drivers. When an event occurs, the device driver goes from the tri-state condition to a high state, the two current output drivers overcoming the single bias driver to force a high state. If subsequent devices trigger, it simply forces an even higher state to the voltage limits of the driver.

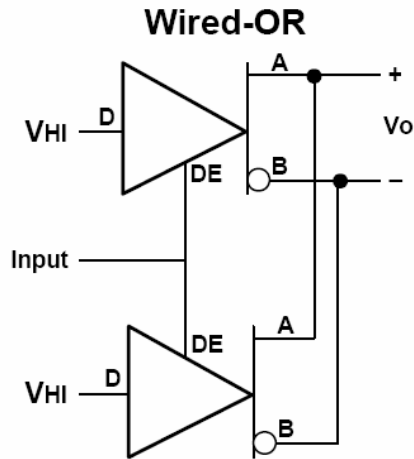

Figure 5. LXI device trigger bus drivers set to Wired OR mode. The trigger input from the LXI device either enables or disables both of the drivers. If they are disabled their output is tri-state and the bus state is determined by another LXI device (the Bias Device). If they are enabled the high inputs to the drivers force the trigger bus to the high state, the outputs can always overcome one driver set to the low state (the bias device)

This operation meets the requirement to start an action on the first device to trigger. The alternative case of starting on the last device to trigger is met by reversing the operation of the Wired OR trigger. A bias device is used in the same way, all the devices participating are set to the high state with two drivers, the last one to release the bus (go to tri-state) allows the bias device to force the bus to the low state.

This method of operation provides a robust way of implementing Wired OR with a performance significantly better than that achieved on VXI. Typically the Wired OR modes can support pulse widths on the trigger bus about twice the duration that can be supported in the driven mode. The limitation on speed is due to the characteristics of the driver when it goes to and from the tri-state condition.

Wired OR Bias Device

The bias device can be any LXI device on the LXI trigger bus and may optionally participate in the Wired OR triggering event with the other devices. In cases where there are devices that do not need to actively participate in the trigger event in many ways it may be simpler if the bias device is chosen to be one of those devices.

However, it is possible that all the devices connected to the trigger bus are participating in the Wired OR triggering. In this case the operation of the Wired OR Bias Device has to be slightly different; it needs to actively drive the bus either low (when it would have been tri-state) or high. The Wired OR functional result is then exactly the same, but the Wired OR Bias Device needs to operate in the same way as it would in the Driven Mode. Consequently if an LXI Device is set to Wired OR but is also set to be the bias device it must operate in the same way as the driven mode.

Trigger modes.

LXI devices on the trigger bus can be set to various modes of operation. The triggers can be set to be positive or negative edge triggered or to be level dependent.

Edge triggered events are typically used for most applications and as shown in the Wired OR case there is a need to detect positive or negative edges to distinguish the two use case examples.

Level Triggered events are typically used when a gated function is required, an activity occurs while the trigger bus is set in a high or low state. Examples might include the measurement of frequency during a specified time interval on a pulsed signal, or the measurement of signal level during that same interval.

Trigger Bus Length Limitations.

The trigger bus length is limited by a number of factors. The distance is limited by the high frequency losses of the trigger bus cable, the longer the cable length the greater the losses and the wider the minimum pulse width that can be supported. In addition there is a limit on the number of LXI Devices that can be connected. The bias and leakage currents of receivers and drivers can cause some offset in the DC levels, so the recommended maximum number of devices (nodes) on the bus is limited to 16 (the M-LVDS standard limits this to 32, but the LXI bus uses two drivers and receivers for each device channel to support the Wired OR mode).

This limitation meets most expected requirements for the LXI trigger bus, but some applications may require additional capability for adding further devices. Consequently the standard defines another type of LXI device, the Star Hub.

Star Hub

The Star Hub allows a number of trigger bus daisy chains to be connected to it. Each of these chains behaves as a separate entity exchanging driven mode or wired OR trigger signals. Each chain is terminated at one end by an LXI Terminator and at the other end by the Star Hub.

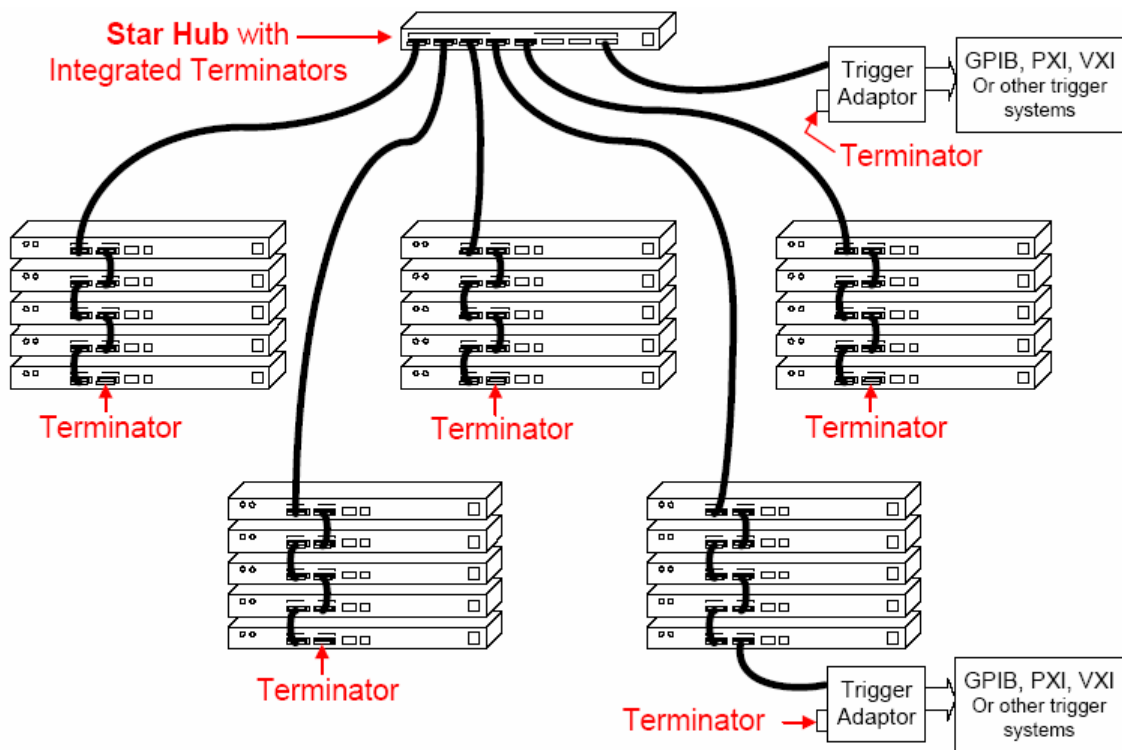

Figure 6 A trigger bus arrangement that includes a Star Hub that can provide a way of isolating daisy chains of trigger busses from each other, provides a means of expanding the number of allowed devices and may provide a method of logically gating daisy chains together.

The Star Hub can then provide a means of connecting chains together via a buffered switch. The direction of the buffer switch has to be fixed (it cannot allow bi-directional signals without causing latch up) so this means that care has to be taken to ensure that the directional nature of the signal does not prevent correct operation of the trigger signal (for example if the direction is from Chain 1 to Chain 2 an event on Chain 2 is not received on Chain 1). The Star Hub can use other physical channels to provide bridging across the chains if the Hub has the required functionality.

Aeroflex, Inc.
Agilent Technologies
Keithley Instruments, Inc.
Measurement Computing Corp.
Pickering Interfaces Ltd
Racal Instruments
Rohde & Schwarz GmbH & Co KG
VXI Technology, Inc.

Anritsu
Bruel & Kjaer S & V

ADLINK Technology, Inc.
Analogic Sky
BAE Systems
California Instruments
Complete Networks, Inc.
Elgar Electronics
Fluke Corporation
GOPEL electronic GmbH
IOTech, Inc.
Lambda Americas
Pacific Power Source, Inc.
Phase Matrix, Inc.
Teradyne
The Math Works
Universal Switching Corporation
Venture Design Services, Inc.
ZTEC Instruments

Acqiris
AMREL
Data Translation
Department of Defense (DoD)
Electronic Systems Innovation
Kepeco, Inc.
Pacific MindWorks
Shaanxi Hitech Electronic Co., Ltd
Symtx, Inc.
Yokogawa Electric Corporation